

ISBAS: An Infrared Sensor Burglar Alert System.

J.C. Osuwa, Ph.D. * and U. Divino, B.Sc.

Department of Physics, Michael Okpara University of Agriculture, Umudike,
PMB 7267, Umuahia, Abi State, Nigeria.

*E-mail: jeremiahosuwa@yahoo.com

ABSTRACT

A burglar alert system using infrared sensors and detector mechanisms has been constructed and tested. A special feature of the system is the detection of human motion across the path of the infrared sensor with a relay output that activates an alarm. The system's simple operation is powered by a 12 volt DC battery, from which power is drawn mainly when detection is made by the primary sensing device. Effective detection of human motion and its low power consumption are ensured by the passive nature of the sensor component.

(Keywords: infrared sensor, ISBAS, LED, relay, alarm, low power consumption)

INTRODUCTION

Amid steady growth in the world's population with non-commensurate employment opportunities and the pressures of a more complex society, the incidences of human intrusion and burglaries in private and public places are on the increase. Heightened security concerns at homes, banks, shopping malls, schools, offices, etc., have led to a continued search for different and improved security devices. Such concerns are apparent in the form of installations of remote cameras, the presence of security guards, and other monitoring devices and alarm systems, which are in constant use (Hart, 1995).

However, many such devices and services are relatively costly, and usually require a high and steady power supply for their operation (Hart, 1995). An Infrared Sensor Burglar Alert System (ISBAS) which has been constructed and tested offers the advantages of low cost and low power consumption in its operation. This concept is based on the fact that virtually all matter radiates infrared at all times and at various ranges (Hebert 1972 and Cohen et al., 1975). Thus, the human

body emits some form of thermal radiation which is detectable on an appropriately fabricated sensor. The primary sensing component is of a passive nature (Hart, 1995 and Adams, 1997), and is activated by the infrared radiation emitted by any intruder within its range of coverage, thus rendering the system difficult to detect. In normal use, relatively low power is required, as the additional power required to energize the alarm or buzzer, is only supplied subsequent to any detection by the primary sensor. This feature makes the device practical for remote locations or in areas with irregular power supplies.

COMPONENTS AND DESIGN SPECIFICATION

The Sensor Circuit

The sensor circuit in ISBAS operates a full wave detection of infrared wave from a source. It is made up of two pins, of which pins 1 and 2 are connected on the horizontal plane as shown in Figure 1.

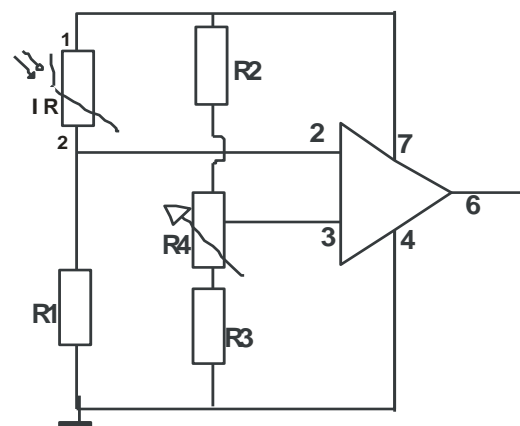

Figure1: IR Sensor Circuit in ISBAS.

In addition, the sensor has two elements connected in a voltage-bucking configuration. This arrangement cancels signals caused by vibration and temperature changes within the sensor due to sunlight. A human being passing in front of the sensor will activate the first element and then the other, whereas other sources will affect both elements simultaneously and be cancelled out. Thus, for any horizontal human motion across the range of the sensor, the elements are sequentially exposed to infrared. (Glolab, 2005).

ISBAS Switch Selection

ISBAS makes use of three switching circuits. The function of the circuit is to turn ON and OFF the current in the circuit. A 12-volt relay is used to sustain the buzzer once the micro-switch is released, whenever the sensor detects human motion. Figure 2 is a representation of the relay switch in ISBAS circuit.

A relay is an electrically operated switch. Current flowing through the coil of the relay creates a magnetic field, which attracts a lever and changes the switch contacts. The coil current can be ON or OFF so relays have two switch positions and they are double throw (changeover) switches. Relays allow one circuit to switch a second circuit, which can be completely separate from the first. For example, a low voltage battery circuit can use a relay to switch a 230V AC mains circuit. There is no electrical connection inside the relay between the two circuits; the link is magnetic and mechanical.

The coil of a relay passes a relatively large current; typically 30mA for a 12V relay, but it can be as much as 100mA for relays designed to operate from lower voltages. (Hewes, 2007). Relays are usually SPDT or DPDT but they can have many more sets of switch contacts.

Figure 2 shows a working relay with its coil and switch contacts. A lever on the left is being attracted by magnetism when the coil is switched on. This lever moves the switch contacts. There is one set of contacts (SPDT) in the foreground and another behind them, making the relay DPDT. The relay's switch connections are usually labeled COM, NC and NO:

- COM = Common. Always connect to this; it is the moving part of the switch.

- NC = Normally Closed. COM is connected to this when the relay coil is off.
- NO = Normally Open. COM is connected to this when the relay coil is on.

A Transistor (NPN) is also used as a switch in ISBAS circuit design. This operates between two states thus: saturated and cut-off states. The saturated state occurs when both emitter-base junction of a transistor is forward biased. The cut-off state occurs when both junctions are reverse biased. The 741 OP amp IC (chip) cannot provide the actual current required by the mechanical switch (relay), hence the transistor is used to amplify the small IC current to the larger value required for the relay coil.

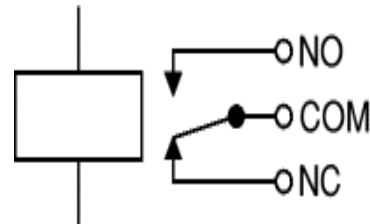

Figure 2: A Relay Switch Representation in the ISBAS.

741 OP AMP IC

741 Op amp is a differential amplifier. The output is directly proportional to the difference in voltage between the two inputs of the Op-amp. They can amplify a voltage from zero frequency to a very high frequency. The Op-amp is usually made of 8-pins, dual-in-line packages (Nelkon et al., 1995). The 741 type was used in this construction (known to be a high performance Op-amp IC).

The pins are numbered anti-clockwise around the IC (chip) starting near the notch or dot. Figure 3 shows the numbering for 8-pin, this principle holds for all sizes.

Light Emitting Diodes (LEDs)

ISBAS makes use of an LED as the pilot lamp for indication when the entire system is ON or OFF. LEDs emit light when an electric current passes through them in a forward biased way (Hewes, 2007). They are tiny light bulbs that fit easily into

electrical/electronics circuits. Solely the movement of electrons in a semiconductor illuminates them. The semiconductor used in LEDs is of different types, but for ISBAS, GaP (Gallium Phosphide) semiconductor was used, which emits red light.

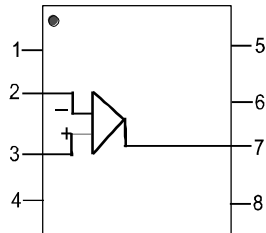

Figure 3: OP Amp 741 Circuit.

The Power Supply

A power supply is an electronic instrument that provides voltage, current, and power to the circuit from an AC power lines or from batteries, suitable for use in various applications to power electronic equipment (Floyd 1991). The ISBAS uses simple DC voltage (9V battery).

RESULTS AND DISCUSSION

ISBAS Main Circuit

The circuit in Figure 4 is the complete circuit diagram of the ISBAS. The positive and negative terminals are clearly shown. The sensor is mainly for detection, the resistors are for filtering and balancing, while the IC, transistor, and the relay are for amplification and switching whenever there is signal from the sensor.

Mode of Operation

The operational diagram of ISBAS is shown in Figure 5. Power is supplied to the circuit through the terminals as shown in Figure 4. This power is fed to pin 1 of the IR sensor. The signal output at pin 2 of the sensor is connected to a 10k-ohm resistor bypassed to the ground.

When the power is supplied to the device, there may be a false triggering of the buzzer. This is because even when there is no signal applied to the input, the internal components of the Op-amp

may supply a small differential voltage to the inputs. Even if the voltage is small, the gain of the Op-amp results in a large offset voltage being present at the output, which is supposed to give out exactly 0V when no signal is recorded. This offset voltage is removed by adjusting the R4 until the output is exactly 0V with no signal present at the input.

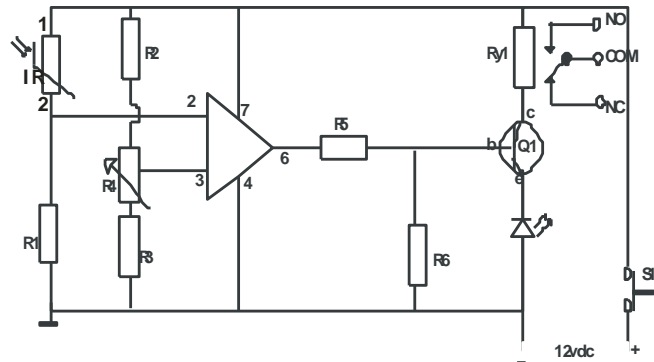

Figure 4: The ISBAS Circuit Diagram.

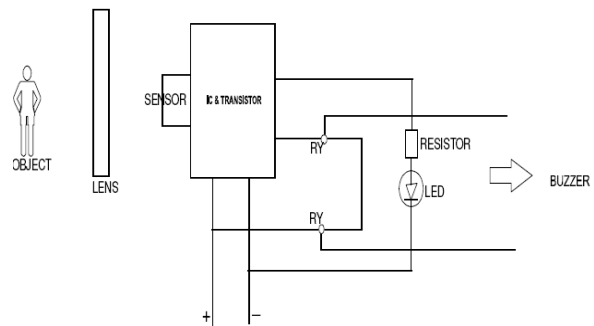

Figure 5: ISBAS Operational Chart.

When motion is detected, the sensor will output a very small voltage transition at pin 2 of the sensor. This voltage is amplified by using an Op-amp IC.

The Op-amp IC supplies power to the transistor through the output pin 6. The transistor controls the flow of power through the relay circuit. The transistor will then make up the actual current required by the relay to trigger on the buzzer, whenever there is signal.

CONCLUSION

ISBAS power supply is a simple DC battery and does not require any inversion or rectification. The sensor ability is efficient, it responds to horizontal motion between 0 – 2m without infrared Fresnel lens and up to 90m with an infrared Fresnel lens when in use.

The ISBAS is reliable and efficient in that it gives a good sensing and detection capability and complexity was reduced in the choice of components. Maintenance and repair can be easily carried out in case of malfunction. The required electronics components listed in Table 1 are readily available and can be sourced locally. It can run for several weeks without exhausting its operating power.

Table 1: Complete List of Components Used.

Name/Description of Components	Quantity	Reference
10K-ohm	2	R1, R5
470 ohm	2	R2, R3
50K-ohm	1	R4
1K-ohm	1	R6
Op-amp IC (UA741CN)	1	IC
NPN Transistor (BC08)	1	Q1
LED (red)	1	D1
Relay (JZC-20F)	1	RY1
Infra Red Sensor	1	IR
Power Switch (thump)	1	S1

ISBAS is designed to provide good surveillance for any user and it operates automatically once installed with the sensor concealed at the entrance of facility requiring protection.

REFERENCES

- Adams, J. 1987. *Identifying Electronics Components Passive*. Prompt Publications and Howard W. Sams and Company. 12-33
<http://www.electronics-lab.com/articles/basics/components>.
- Cohen, A. and Caligiuri, H.J. 1975. *Body Exposure Indicator*. US Patent No. 3,924,130, December 2, 1975.
<http://freepatentsonline.com/392413/html>

- Floyd, L.T. 1991. *Electronics Fundamentals Circuit, Device and Applications*. Merrill Publishing Company: Columbus, OH. 883.
- Globab Corporation. 2005. *Infrared Motion Detector Manual*. Globab Corp.: Bangalore, India.
<http://www.global.com/asp>
- Hart, F.J. 1995. *Interactive Surveillance Device United States*. Patent 5473368.
<http://freepatentsonline.com/3924130/html>
- Herbert, L.B. 1972. *Infrared Intrusion Detector System using a Single PIR Detector*. November 21, 1972. US Patent No. 3,703,718.
<http://freepatentsonline.com/370371/html>
- Hewes, J. 2007. "Electronics Components". The Electronic Club.
<http://www.kpsecfreeuk.com/>
- Nelkon and Parker. 1995. *Advanced Level Physics (7th Edition)*. CBS Publishers: New Delhi, India. 793.

ABOUT THE AUTHORS

J.C. Osuwa, Ph.D. is a Lecturer of Physics at Michael Okpara University of Agriculture Umudike, Umuahia, Abia State, Nigeria. His research interests are in material science, energy, and electronics and nuclear engineering.

U. Divino, B.Sc. is a former student of the Physics Department, Michael Okpara University of Agriculture, Umudike, Umuahia, Abia State, Nigeria. His research interests are in the areas of electronics and material science.

SUGGESTED CITATION

Osuwa, J.C. and U. Divino. 2010. "ISBAS: An Infrared Sensor Burglar Alert System". *Pacific Journal of Science and Technology*. 11(1): 24-27.



<http://www.akamaiuniversity.us/PJST.htm>