

# Transient Analysis of DFIG and IG during Grid Fault.

Kenneth E. Okedu, M.Eng.

Department of Electrical and Electronic Engineering,  
University of Port Harcourt, PMB 5323, Port Harcourt, Nigeria.

E-mail: [kenokedu@yahoo.com](mailto:kenokedu@yahoo.com)

## ABSTRACT

Doubly Fed Induction Generators (DFIG) are heavily stressed during grid faults, and thus, tend to lose their independent controllability of active and reactive power. A crowbar protection switch can be used to protect the DFIG frequency converters during grid fault. Induction Generators (IG) are also heavily stressed during grid faults, but do not have independent controllability of active and reactive power like the DFIG. This paper investigates the transient stability of DFIG and IG during grid fault. Simulation results in PSCAD/EMTDC show that DFIG is more stable during grid fault because it can assume its steady state after the fault due to the provision of reactive power by its frequency converters, while the IG cannot return to its steady state because its reactive power consumption is high during transient, hence needs external compensation.

(Keywords: wind energy, doubly fed induction generator, induction generator, grid fault, wind turbine)

## INTRODUCTION

Wind energy technology has experienced important gains over the last few decades [7] due to the technological improvement of wind turbines from fixed speed to variable speed. The Doubly Fed Induction Generator (DFIG) has very attractive characteristics as a wind generator in the fast growing market. The fundamental feature of the DFIG is that the power processed by the power converter is only a fraction of the total power rating, that is, typically (20-30%), and therefore its size, cost and losses are much smaller compared to a full size power converter [1, 4].

A wind turbine with DFIG uses a frequency converter and a pitch blade actuator to control directly the generator speed and wind turbine output [2]. The frequency converter has the Rotor

Side Converter (RSC) and the Grid Side Converter (GSC). The RSC controls independently, active and reactive power, while the GSC also controls the active power flow through the converter by controlling the DC-link voltage to unity. The use of a crowbar switch for DFIG protection has been reported in [1, 2, 3, and 4].

DFIG can operate at a wider range of speeds depending on the wind speed or other specific operation requirements. Thus, it allows for a better capture of wind energy [6, 11, and 13], and dynamic slip control. Pitch control may contribute to rebuilding the voltage at the wind turbine terminals and maintaining the power system stability after clearance of an external short-circuit fault [2]. In addition, DFIGs have shown better behavior concerning system stability during short-circuit faults in comparison to IG, because of their capability of decoupling the control of output active and reactive power.

The superior dynamic performance of the DFIG results from the frequency converter which typically operates with sampling and switching frequencies of above 2 kHz [1]. At lower voltages, down to 0%, the IGBTs (Insulated Gate Bipolar Transistors) of the DFIG are switched off and the system remains in standby mode [8-10, and 12]. If the voltages are above a certain threshold value during fault, the DFIG system is very quickly synchronized and is back in operation again.

On the other hand, IGs are used in general as FSMT generators due to their superior characteristics such as brushless and rugged construction, low cost, low maintenance, and operational simplicity [14], but these require large reactive power to recover the air gap flux when a short-circuit fault occurs in the power system. IG technology has limited ability to provide voltage and frequency control. The installation of power electronic devices and reactive power

compensation units like STATCOM, ECS, SMES in a FSWT wind farm increases the system overall cost and the amount of dynamic reactive compensation depends generally on the wind turbine technology and is influenced by the wind turbine electrical and mechanical parameters [6].

This paper presents the transient analysis of the DFIG and the IG during grid fault. Simulations were carried out in PSCAD/EMTDC [5]. The simulation results show the DFIG is more stable than the IG during grid fault because it can provide sufficient reactive power from its frequency converters.

### TURBINE MODEL

A wind turbine catches the wind through its rotor blades and transfers it to the rotor hub. The rotor hub is attached to a low speed shaft through a gear box. The high speed shaft drives an electric generator which converts the mechanical energy to electrical energy and delivers it to the grid [1 and 4]. As the wind speed varies, the power captured, converted and transmitted to the grid also varies.

$$P_{wind} = \frac{1}{2} \rho_{air} A_{rotor} C_p(\lambda, \beta) V_w^3 \quad (1)$$

$$T_t = \frac{\pi \rho R^2}{2} V^3 C_p(\lambda, \beta) / \omega_m \quad (2)$$

$$\lambda = R_{blade} \omega_m / V_\omega \quad (3)$$

Where  $\rho_{air}$  is the air density in  $kg/m^3$ ,  $A_{rotor}$  is the area covered by the rotor blades,  $C_p$  is the performance coefficient of the turbine,  $V_\omega$  is the wind speed.

$$C_p(\lambda, \beta) = 0.5(\Gamma - 0.02\beta^2 - 5.6)e^{-0.17\Gamma} \quad (4)$$

$$\Gamma = \frac{R(3600)}{\lambda(1609)} \quad (5)$$

The schematic diagram of the DFIG and IG are shown in Figure 1, while Figure 2 shows the DFIG system with the crowbar protection scheme.

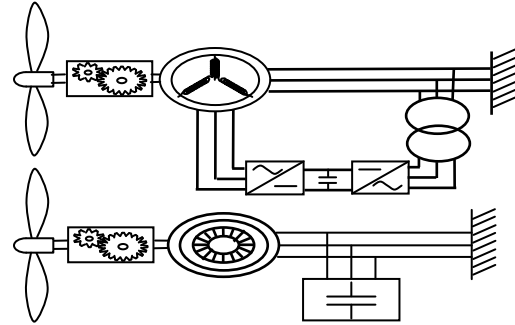


Figure 1: Schematic Diagram of DFIG and IG.

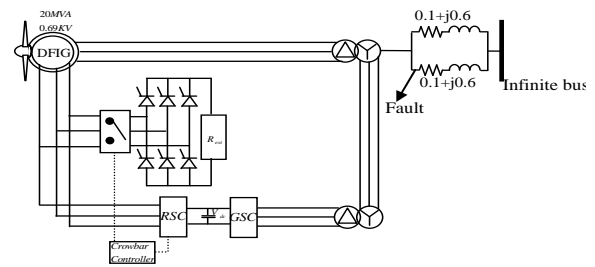


Figure 2: Model System of DFIG with Crowbar.

The parameters of both generators are given in Table 1.

Table 1: Parameters of DFIG and IG.

Rated Power	30MVA(IG)	20MVA(DFIG)
Rated Voltage	690V	690V
Stator Resistance	0.01pu	0.01pu
Stator Leakage Reactance	0.07pu	0.15pu
Magnetizing Reactance	4.1pu	3.5pu
Rotor Resistance	0.007pu	0.01pu
Rotor leakage Reactance	0.07pu	0.15pu
Inertia Constant	1.5secs	1.5secs

## THE DFIG CONTROL SYSTEM

They are two control sections of the DFIG; the Grid Side Converter and the Rotor Side Converter.

### Grid side converter of the DFIG

In Figure 3 the Phase Lock Loop (PLL) is used to provide the angle  $\theta$  and  $\theta_s$  is the effective angle for the abc-to-dq0 (and dq0-to-abc) transformation. The direct axis component is used to regulate the dc-link voltage ( $E_{dc}$ ) to 1pu. The actual DC link voltage ( $E_{dc}$ ) is compared to the reference and the error is sent to the first PI controller to determine the reference current ( $I_d^*$ ) for the direct axis component. The  $I_d^*$  is compared to the actual value of  $I_d$  and the error is sent to the second PI controller to determine the reference voltage  $V_q^*$  for the direct axis component sent to the Pulse Width Modulator.

In normal operation the RSC already regulates the power factor of the DFIG, so there is no need for reactive power regulation by the grid side converter. Thus,  $Q_{ref} = 0$ , in Figure 3,  $Q_{ref}$  is compared to the actual value of  $Q_{gsc}$  and the error is sent to the first PI controller to determine the reference current  $I_q^*$  for the quadrature axis component. After a dq0- to-abc transformation,  $V_q^*$  and  $V_d^*$  are sent to the PWM signal generator. Finally  $V_{abc}^*$  are three voltages at the GSC output for the IGBT's switching.

### Rotor Side Converter of the DFIG

In normal operation, the RSC regulates the developed electric power ( $P_g$ ) and the absorbed reactive power by the DFIG. In Figure 4  $\theta_r$  obtained from the PLL angle  $\theta$  and the generator rotor position is the effective angle for the abc-dq0 and the dq0-qbc transformations. The direct axis component is used to regulate the generator power factor to 1pu thus; the absorbed reactive power reference ( $Q^*$ ) is equal to zero. The actual absorbed reactive power at the grid connection ( $Q_g$ ) of the DFIG is compared to the reference and the error is sent to the first PI controller to determine the reference current

$i_{dr}$  for the direct axis component. Then,  $i_{dr}$  is compared to the actual value of  $i_d$  and the error is sent to the second PI controller to determine the reference voltage  $V_{qr}^*$  for the direct axis component.

The quadrature axis component is controlled similarly to the direct axis; however, it regulates the electric power to the optimal reference  $P_{opt}^*$ . After a dq0-to-abc transformation,  $V_{dr}^*$  and  $V_{qr}^*$  are sent to the PWM signal generator. Finally,  $V_{abc}^*$  are the three-phase voltages desired at the rotor side converter output for switching IGBTs.

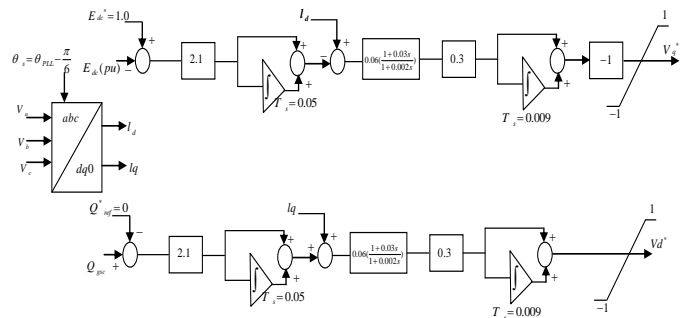


Figure 3: Grid Side Converter Control System.

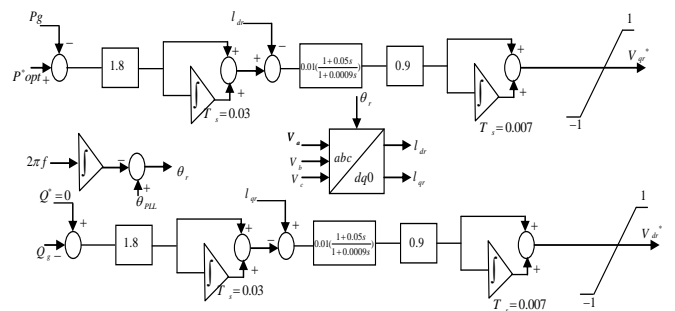


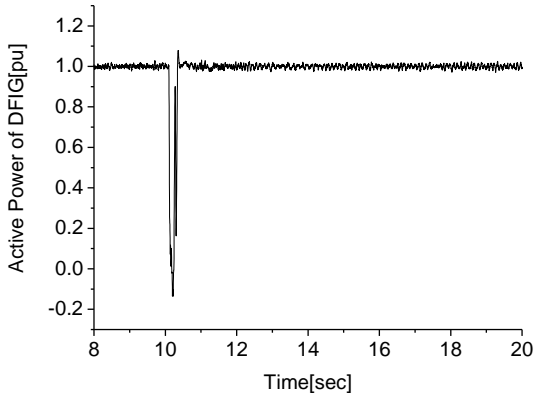
Figure 4: Rotor Side Converter Control System.

## SIMULATION RESULTS

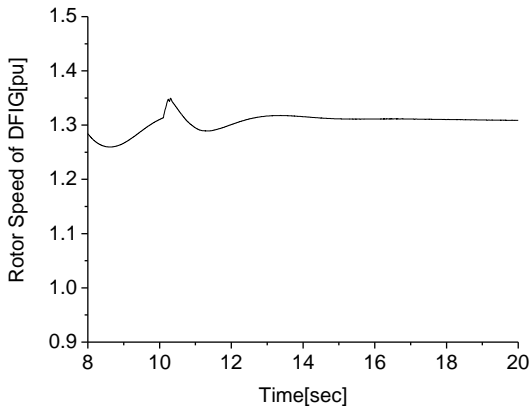
Simulations were run in PSCAD/EMTDC for duration of 20 sec. with a fixed speed above the rated speed for DFIG and at the rated for IG,

because it is assumed the fault is for a short time. A three phase fault was applied at 10.1 sec. and the circuit breakers on the faulted line opened at 10.2 sec. and reclosed at 11.0 sec., respectively. The results for both cases are shown in Figures 5 to 18.

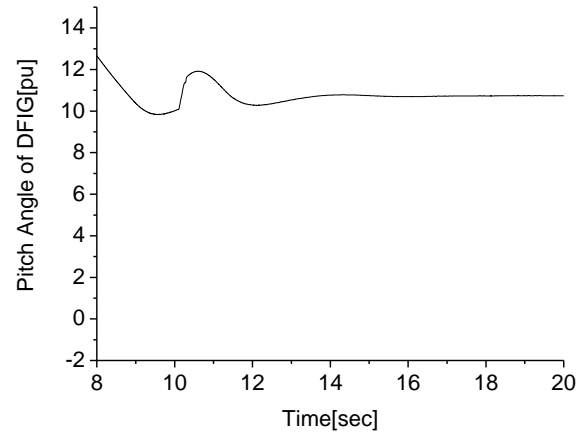
### **DFIG Analysis**



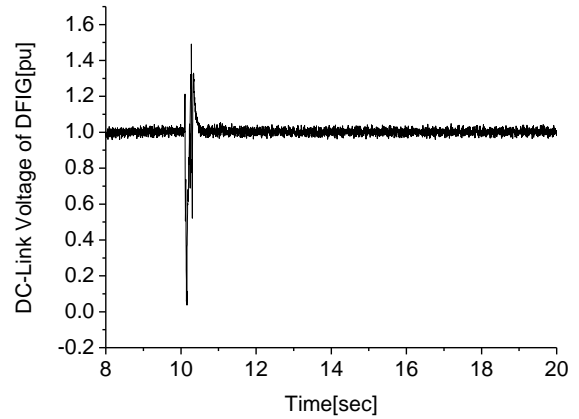
**Figure 5:** Active Power of DFIG.



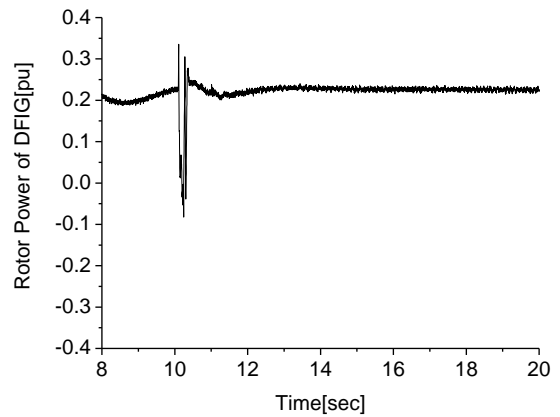
**Figure 6:** Rotor Speed of DFIG.



**Figure 7:** Pitch Angle of DFIG.

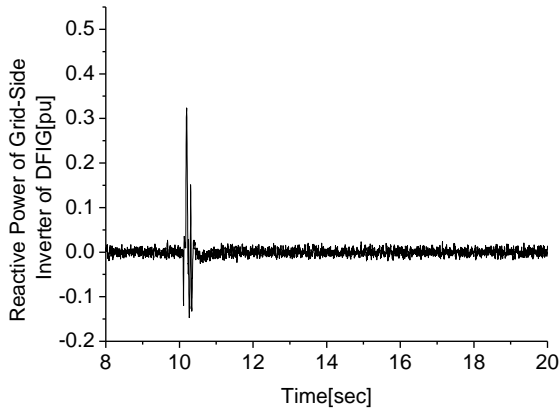


**Figure 8:** DC-Link Voltage of DFIG.

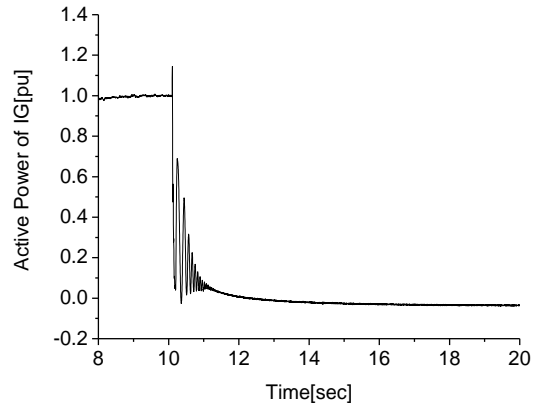


**Figure 9:** Rotor Power of DFIG.

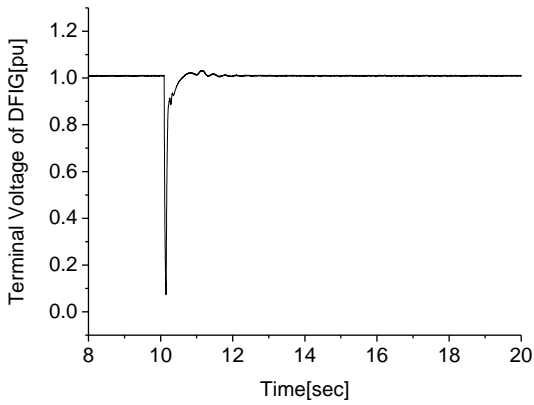
## Induction Generator Analysis



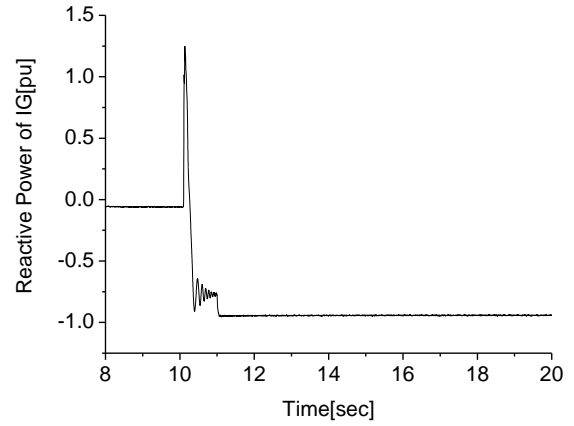
**Figure 10:** Reactive Power of Grid-Side Converter of DFIG.



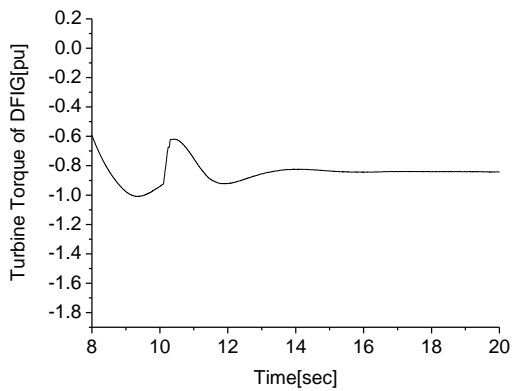
**Figure 13:** Active Power of Induction Generator.



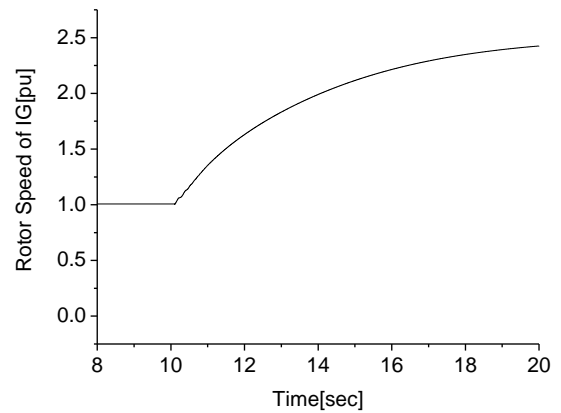
**Figure 11:** Terminal Voltage of DFIG.



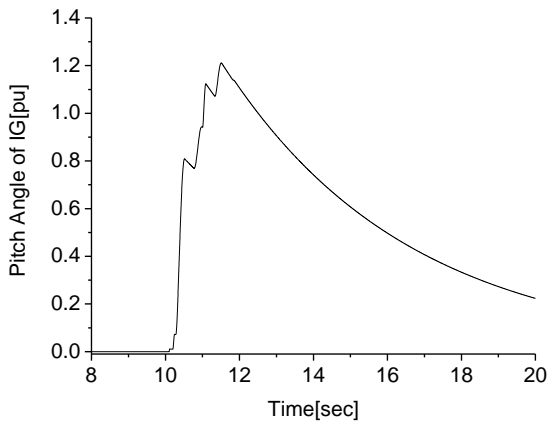
**Figure 14:** Reactive Power of Induction Generator.



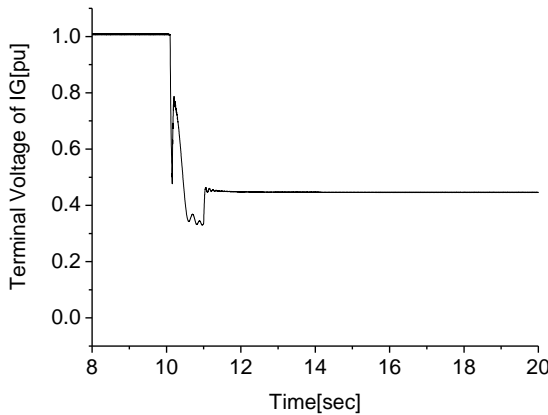
**Figure 12:** Turbine Torque of DFIG.



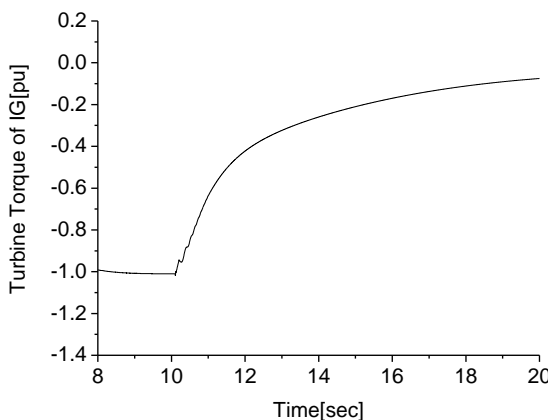
**Figure 15:** Rotor Speed of Induction Generator.



**Figure 16:** Pitch Angle of Induction Generator.



**Figure 17:** Terminal Voltage of Induction Generator.



**Figure 18:** Turbine Torque of Induction Generator.

The results show that the DFIG system was able to recover itself after the grid fault as shown in Figures 5 to 12 because of the reactive power provision from its frequency converters, while the IG was not able to recover itself after the three phase fault in the system because it cannot provide reactive power for itself.

## CONCLUSION

The transient stability of the DFIG and IG has been investigated. The DFIG system is more stable during grid fault in the power system compared to the IG, because it can provide sufficient reactive power to stabilize itself during grid fault hence, commonly in use in the present day for wind turbines.

Despite such characteristics of the IG like brushless and rugged construction, low cost, low maintenance, and operational simplicity, the transient stability of the IG is very poor because it requires large reactive power to recover the air gap flux when a short circuit fault occurs in the power system and also has limited ability to provide voltage and frequency control, unless enhanced by the installation of power electronic devices and reactive power compensation units like STATCOM, ECS, SMES which increases the overall cost.

## REFERENCES

1. El-Sattar, A.A., N.H. Saad, and M.Z Shams El-Dein. 2008. "Dynamic Response of Doubly Fed Induction Generator Variable Speed Wind Turbine Under Fault". *Electric Power System Research*. 78:1240-1246.
2. Sun, T., Z. Chen, and F. Blaabjerg. 2005. "Transient Stability of DFIG Wind Turbines at an External Short Circuit Fault". *Wind Energy Journal*. 8:345-360.
3. Hasan, A.D. and G. Michalke. 2007. "Fault Ride-Through Capability of DFIG Wind Turbines". *Renewable Energy*. 32:1594-1610.
4. Erlich, I., H. Wrede, and C. Feltes. 2008. "Dynamic Behaviour of DFIG-Based Wind Turbine During Grid Faults". *IEEEJ Trans*. 128(4):396.
5. HBDC. 1994. *PSCAD/ETDM Manual*. HVDC Research Center: Manitoba, Canada.

6. Santos, S. and H.T. Le. 2007. "Fundamental Time-Domain Wind Turbine Models for Wind Power Studies". *Renewable Energy*. 32:2436-2452.
7. Blaabjerg, F., F. Iov, and K. Ries. 2002. "Fuse Protection of IGBT Modules against Explosions". PCIM Conference, China.
8. Takahashi, T. 2004. "IGBT Protection in AC or BLDC Motor Drives". Technical paper, International Rectifier: El Segundo, CA.
9. Xie, H. 2006. "Voltage Source Converters with Energy Storage Capability". PhD Thesis, Royal Institute of Technology, School of Electrical Engineering, Division of Electrical Machines and Power Electronic: Stockholm, Sweden.
10. Chowdhury, B.H. and S. Chellapilia. 2006. "Doubly-Fed Induction Generator Control for Variable Speed Wind Power Generation". *Electric Power System Research*. 76:786-800.
11. Haberberger, M. and F.W. Fuchs, 2004. "Novel Protection Strategy for Current Interruptions in IGBT Current Source Inverters". *Proceedings EPE-PEMC*: Oslo, Norway.
12. Karim-Davijani, H., A. Sheikholeslami, H. Livani, and M. Karimi-Davijani. 2009. "Fuzzy Logic Control of Doubly Fed Induction Generator Wind Turbine". *World Applied Science Journal*. 6(4):499-508.
13. Simoes, M.G. and F.A. Farret. 2004. "Renewable Energy System Design and Analysis with Induction Generators". *Power Electronic and Application Series*. CRC Press: Boca Raton, FL.
14. Muyeen, S.M, M.A. Mannan, M.H. Ali, R. Takahashi, and J. Tamura. 2006. "Stabilisation of Wind Turbine Generator System by STATCOM". *IEEJ Trans, P.E*. 126-B(10):1073-1082.

interest are power system stability and renewable energy.

### SUGGESTED CITATION

Okedu, K.E. 2010. "Transient Analysis of DFIG and IG During Grid Fault". *Pacific Journal of Science and Technology*. 11(1):107-113.

 [Pacific Journal of Science and Technology](http://www.akamaiuniversity.us/PJST.htm)

### ABOUT THE AUTHOR

**Kenneth Okedu**, is currently a Ph.D. student at the Kitami University of Technology, Hokkaido, Japan. He obtained his Bachelor and Masters degrees in Electrical and Electronic Engineering, University of Port Harcourt, Nigeria, where he was retained as a lecturer. His areas of research