

Thermal Conductivity Estimates in the Niger Delta Using Lithological Data and Geophysical Well Logs.

Idara O. Akpabio, Ph.D.

Exploration Department, Shell Petroleum Development Company, Port Harcourt, Nigeria.
Permanent Address: Department of Physics, University of Uyo, Nigeria.

E-mail: idara_akpabio@yahoo.com

ABSTRACT

Thermal rock properties and heat flow were determined from two hundred and sixty wells in the Niger Delta. The new thermal data provides new aspects for the determination of heat flow and for thermal evaluation of basins. A map has been constructed using lithologic data and geophysical well logs. The thermal conductivity for sand and shale, the predominant lithology in the Niger Delta shows wide variations from well to well. In the Benin formation, thermal conductivity has an average of 8 W/mK. The lowest values are found offshore westward, while highest values occur northward. The conductivity values however decreases approaching the marine paralic section with an average value of 5 W/mK, this is the region of interest however. The thermal conductivity values have been used in calculating heat flow. A significant regional trend of relatively low heat flow at the central part (20 – 30 mW/m²), increases both seaward and northward (40 - 55 mW/m²) is observed in the map area. The lowest heat flow is observed in the central part of the study area. The highest heat flow is in the northern part, with values exceeding 50 mW/m². Knowledge of thermal properties has direct relevance for hydrocarbon exploration.

(Keywords: thermal conductivity, heat flow, sand percentage, temperature)

INTRODUCTION

The thermal conductivity of rocks is one of the major factors that affect temperature in sedimentary basins and, therefore, should be addressed in basin analysis. Akpabio and Ejedawe, (2001) describe this effect on the temperature distribution to be significant (50 – 80%). As a result of thermal conductivity, thermal structure of a basin may change laterally and

vertically even if the heat flow into the basin is regionally the same, Norden and Forster (2006).

The variability of heat flow in most basins must arise from some combination of at least the following four principal influences: heat redistribution by migration of formation fluids (hydrodynamic effect); variations in conductivity and heat generation in the sedimentary succession; variations in the heat generation of crystalline basement; and, variations in mantle heat flow Majorowicz (2005).

In this paper, we present thermal conductivity profiles from lithologic information and continuous temperature data across the Niger Delta basin covering the area bounded between latitudes 5°38' – 6°00'N and longitudes 5°38' – 6°43'E, (Figure 1).

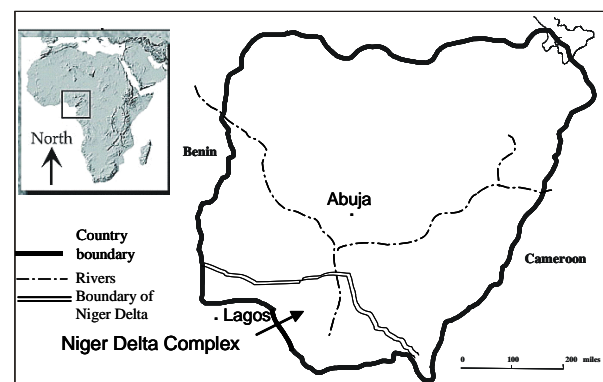

Figure 1: Location Map of the Niger Delta Region.

GEOLOGIC SETTING

The geologic setting of the Niger Delta Basin is well documented in standard articles (Reijers et.

al., 1997). In summary, three main lithostratigraphic units have been recognized and were laid down under Marine, Transitional and Continental environments corresponding to Akata, Agbada, and Benin formations.

Akata Formation: This is the basal sedimentary unit. The formation is mainly composed of marine shales. The shales are under compacted and may contain abnormally high-pressured siltstone or fine-grained sandstone. It is believed to be the main source rock for the Delta and the basic unit of the Cenozoic complex. It ranges in thickness from approximately 600m to 6,000m.

Agbada Formation: It consists of alternations of sands, sandstones and siltstones. Due to differential subsidence variations in the sediment, Agbada sandstone is poorly sorted with various grain sizes ranging from fine to coarse while its sands contribute the main hydrocarbon reservoir of the Delta. The consolidated sands have a calcareous matrix, shale fragments and glauconite occur while lignite streaks and limonite are common. The thickness ranges

approximately from 2,880m – 4,200m while the age ranges from mid – Miocene to late Miocene.

Benin Formation: This is the uppermost limit of the Delta as thick as 3,000m and extends to about 9,730m out of the Bonny beach. The sands and sandstones range from coarse to fine and are poorly sorted showing a little lateral continuity, Reijers et al (1997).

DATA

1. The sand/shale percentage data were interpreted from three types of lithologic logs; resistivity, gamma ray and spontaneous potential for two hundred and sixty wells widely spread across the Niger delta (Figure 2).

They all exhibit different responses but complimentary roles.

- (a) Resistivity logs are electric logs used to indicate permeable zones (such as sand) from impermeable zones (such as shale).

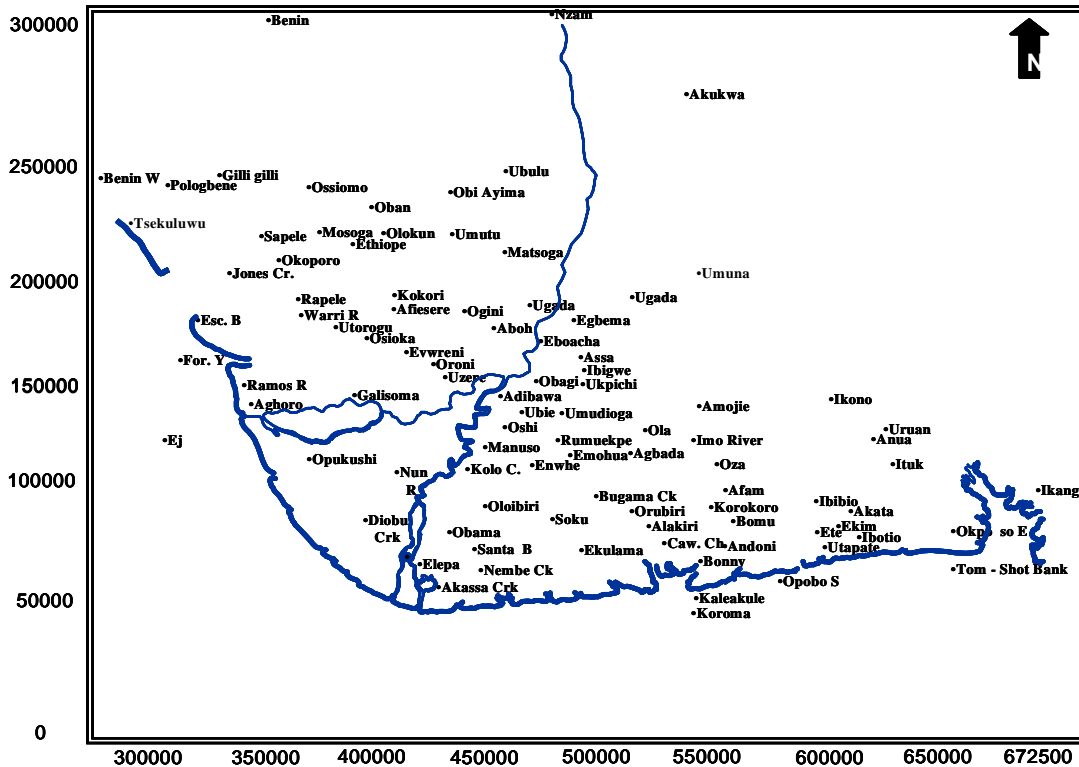

Figure 2: Location Map of the Niger Delta showing Wells Used in the Study.

(b) Gamma ray log is a measurement of intensity of natural gamma radiations spontaneously emitted by some radioactive elements like shales and clay, Schlumberger (1989). Shale free sandstones have low concentration of radioactive material.

(c) A spontaneous log primarily identifies impermeable zones (shale) from permeable zones (sand).

- Continuous temperature logs were also interpreted for same number of wells. The temperature logs were more reliable because they were recorded several months after wells have been drilled, so formation had stabilized. They were more reliable than Bottom Hole Temperatures.
- Interval transit times were also collected for the same wells; it assisted in explaining certain anomalies. Interval transit time is the reciprocal of sonic velocity. It is determined from sonic well logs and used to estimate porosity of formations

THERMAL CONDUCTIVITY / HEAT FLOW DETERMINATION

The Geometric Mean Model proposed by Chapman et al 1984 was used in this study. For rock porosity ϕ , the bulk conductivity of the porous rock K_r may be calculated as the geometric mean from phase conductivities, according to their fractional volume;

$$K_r = K_w \phi + K_s (1 - \phi)$$

$$\phi = 0.25 \exp(-z / 3.0),$$

where ϕ , = porosity,

K_w = conductivity of the fluid,

Z = depth in km, K_s = matrix conductivity

$$K_w = 0.56 + 0.003T^{0.827}, \text{ for } 0 \leq T \leq 63^\circ\text{C}$$

$$K_w = 0.481 + 0.942 \ln T, \text{ for } T > 63^\circ\text{C}$$

Water has a given temperature dependence, although the effect is very small relative to temperature effects on the matrix conductivity.

Water has a conductivity of 0.56 W/mK at 0°C that increases to 0.68 W/mK at 100°C. Water temperature conductivity quoted by Brigaud et al., (1990) are approximated by the following functions,

$$K_w = 0.56 + 0.003T^{0.827}, \text{ for } 0 \leq T \leq 50^\circ\text{C}$$

$$K_w = 0.442 + 0.519 \ln T, \text{ for } T > 50^\circ\text{C}$$

K_s = matrix conductivity given as:

$$K_{sT} = K_{s20} \cdot (293 / (273 + T))$$

Where K_{sT} is the matrix conductivity at temperature T (°C).

The Geometric mean model formed the basis of an algorithm called LITHTEMP compiled by Ejedawe (1997). Figure 3 shows the flow line of the algorithm.

In Figure 3:

f_s, f_{sh} = fractional percentage of sand and shale (interpreted from gamma ray and resistivity logs for the eighty three wells).

f'_s, f'_{sh} = surface porosity of sand and shale (0.4 and 0.7, Ejedawe 1997).

f_{oi} = surface porosity of the interval.

f_i = porosity of the ith interval

h = depth of selected interval (100ft).

C_s, C_{sh} = compaction coefficient of sand and shale (0.0012 and 0.0024, Ejedawe 1997).

C_i = compaction coefficient of interval.

K_{mi} = matrix thermal conductivity of the ith interval

K_s, K_{sh} = assumed value of reference matrix thermal conductivity for sand and shale (6.1W/mK and 2.1W/mK respectively, Akpabio, 1997).

K_{fi} = thermal conductivity of water at temperature of interval.

K_i = effective thermal conductivity.

T = surface temperature.

**Thermal conductivity calculation
LITHTEMP
(Flow line)**

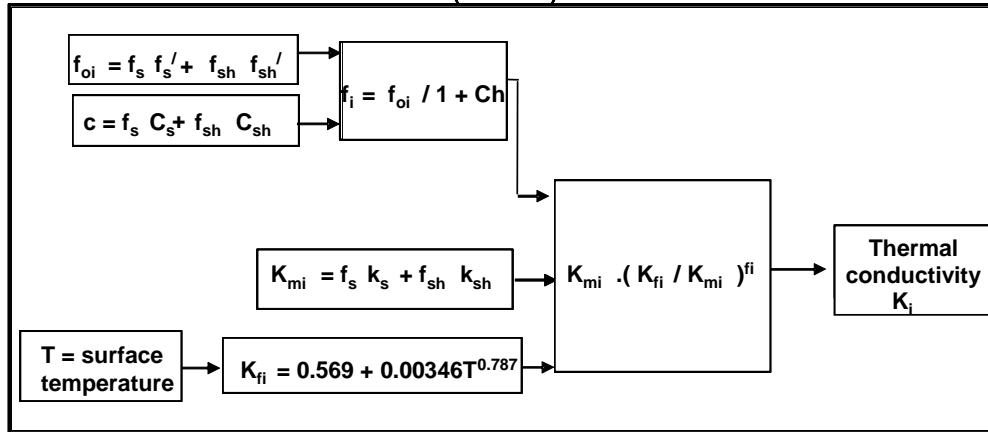

Figure 3: Thermal Conductivity Calculation.

Heat flow q_i in any interval is then computed from the effective thermal conductivity K_i of the interval using the simple relation:

$$q_i = g_i K_i$$

where g_i is the geothermal gradient of the interval. The geothermal gradient values used in this study were obtained from Akpabio et al. (2003).

The porosity calculation in the formula is based on the assumption that incremental change in porosity is proportional to change in load and to the ration of void space to skeleton volume.

RESULTS / DISCUSSION

It is important to note that due to differences in the heat flow between Formations, data were collected and results are presented in two different depth sections. In the Benin Formation (top to base continental sequence) and from base continental (mostly from 2000ft) to continuous shale.

Thermal Conductivity:

The thermal conductivity for sand and shale, the predominant lithology in the Niger Delta shows wide variations from well to well. Figures 4 and 5 show these areal variations. In the Benin formation, conductivity ranges from 5 ± 2 W/mK

to 10 ± 4 W/mK with an average of 8 W/mK. The lowest values found offshore westward, while highest values occur northward.

The conductivity values however decreases when one approaches the marine paralic section with an average value of 5 W/mK.

However, some wells exist where thermal conductivity of the shallow section is lower than in the deeper section or conversely the heat flow is greater in the shallow portions of the well. Good examples are dominant in the offshore depobelt. Depobelts are basinal areas emphasising genetic relationship between a structure and stratigraphy.

There is a corresponding decrease in sound travel time in such areas (Figure 6); this may be associated with loss or absence of porosity within the interval. The regional distribution of thermal conductivity shows a variation with well location (Figure 7). These variations are inferred to relate to variations in the lithologies encountered.

In Brunei continental margin, Zielinski et al (2007) reports that active fluid loss from depth (porosity) in the Baram delta pseudo-accretionary prism is the prime factor influencing the distribution of heat flow and thermogenic surface hydrocarbons. Thermal conductivity varies with depth due to variable lithology and water content, Majorowicz et al. (2005).

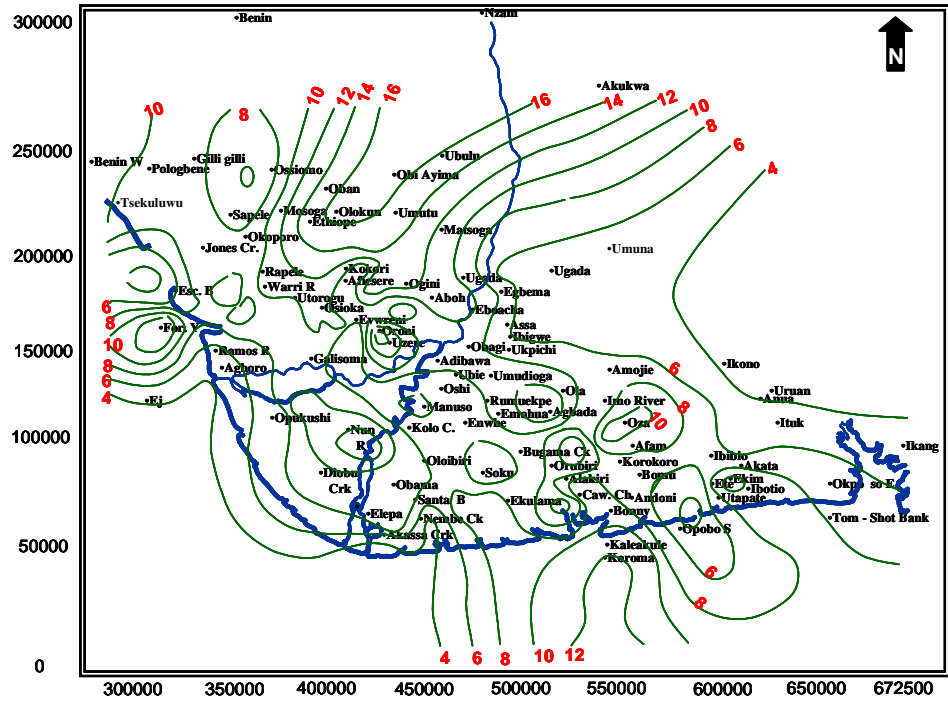

Figure 4: Thermal Conductivity Profile in the Study Area (Shallow Section).

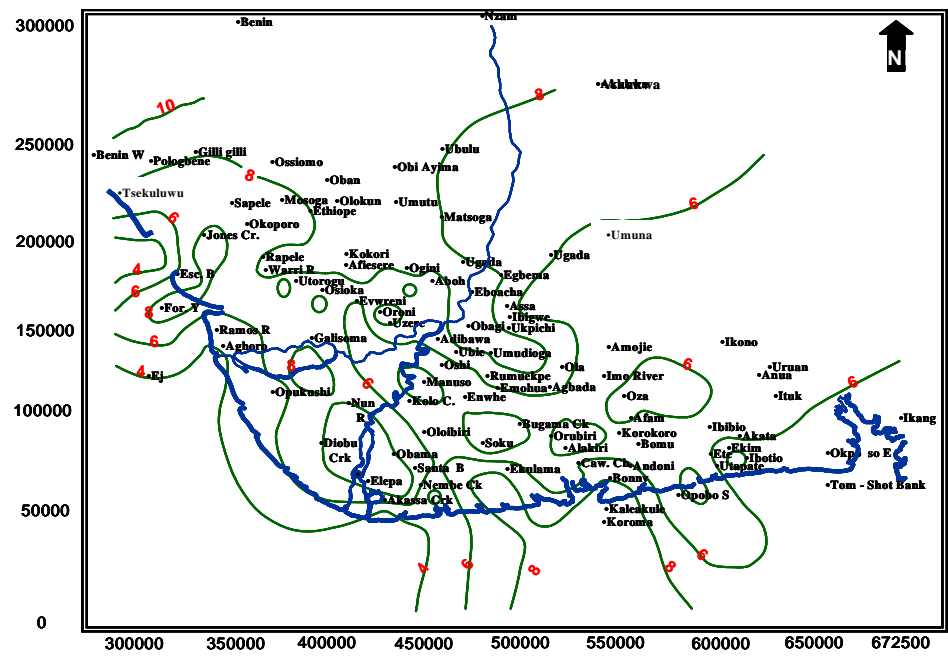

Figure 5: Thermal Conductivity Profile in the Marine Paralic (Deeper Section).

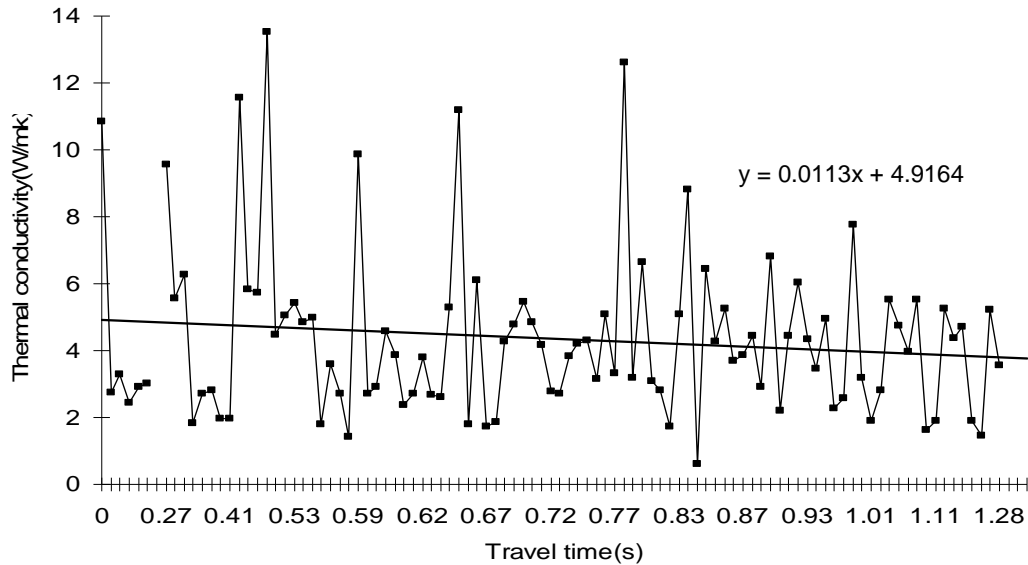

Figure 6: Thermal Conductivity (Sand and Shale) vs Travel Time.

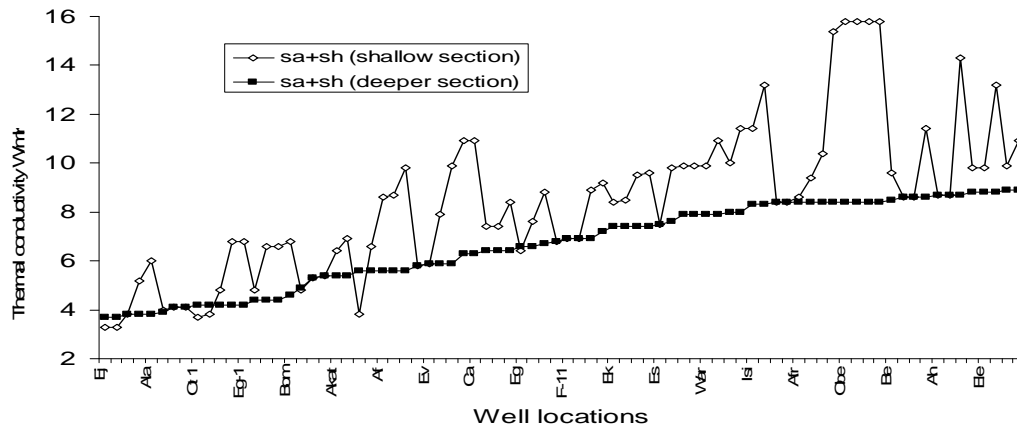

Figure 7: Thermal Conductivity as a Function of Well Location.

The results here further confirm the fact that all pore fillers are very poor conductors, i.e. thermal conductivity decreases with increasing porosity.

Berge et al (1995) also showed that porosity decreases with increase in velocity and conversely the interval transit time. It is here noted that thermal conductivity exhibits no direct or distinct relationship with sound travel time.

However, in Figure 6, based on the trend line equation, $y = 0.0113x + 4.9164$, travel time decreases correspondingly with low thermal conductivity. Since velocity increases with more compaction, transit time conversely reduces.

Figure 7 shows thermal conductivity in the shallow Benin formation being higher (average of 8 W/mK) than in the deeper marine paralic

section (average of 6 W/mK). This presentation suggests or otherwise confirms the fact that Benin sands are more conducting than the marine shales.

Figure 7 also confirms the fact that the high conductivity of the well conducting rocks decreases with increasing temperature, since temperature increases with depth. This is clearly shown as data for the deeper section has low thermal conductivity. This implies that large conductivity contrasts between various rock types are a shallow phenomenon (as can be seen on the scattered graph).

In the works of Kim and Lee (2007), they found that the shallow Moho depth area of Republic of Korea tends to have higher heat flow than the area of thick crust, a further confirmation of Figure 7.

It is worthy to point out the great thermal conductivity anisotropy exhibited at the shallow depth. Thermal conductivity anisotropy is a function of rock mineralogy and fabric (Pribnow and Umsonst, 1993), particularly the bedding planes of the rock. However, in the works of Davis et al (2007), he documents that thermal conductivity anisotropy is especially pronounced in shales and clay – rich rocks. On the contrary

Figure 7 shows less anisotropy in the shale prone area i.e. deep section of the formation.

Thermal conductivity and heat flow has a close relationship. Figure 8 shows that where there is relatively low conductivity, heat flow is also low. Similarly, where there is relatively high conductivity, heat flow is also high in the marine shale formation.

The Benin formation however shows a less definitive relationship compared to the marine section (Figure 9).

Heat Flow:

Heat flow varies from 20 to 55 mW/m², with an average of 36 mW/m² but is mostly in the 30 to 45 mW/m² range. Very large variation of heat flow suggests a large imprint of the highly variable heat generation in the upper crust. Also, Majorowicz et al (2005) feels that a hydrodynamic (fluid flow) effect superimposed on a generally high heat flow background (hot crust and upper mantle) is a possible influence. The lowest heat flow is observed in the southern and offshore regions of the study area; Ej and Ea, Nun River and Alakiri. The highest heat flow is observed in the north; Tsekelewu, Benin West and Pologbene, with values exceeding 50 mW/m².

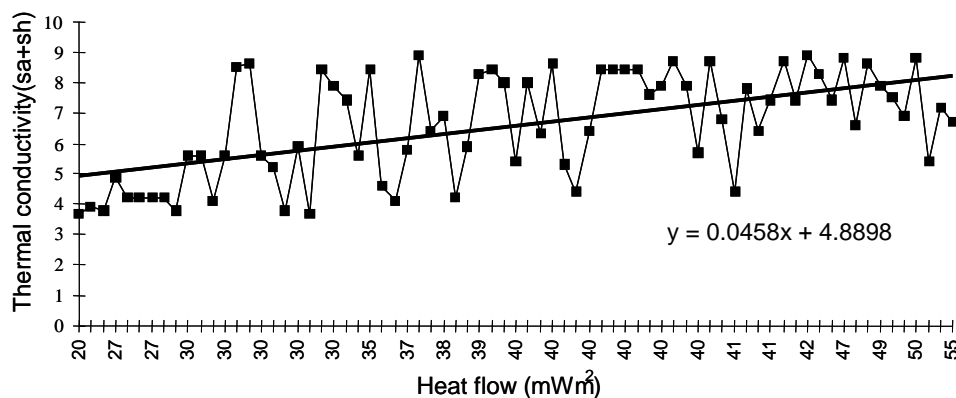

Figure 8: Heat Flow vs Thermal Conductivity (sa+sh) Marine Formation..

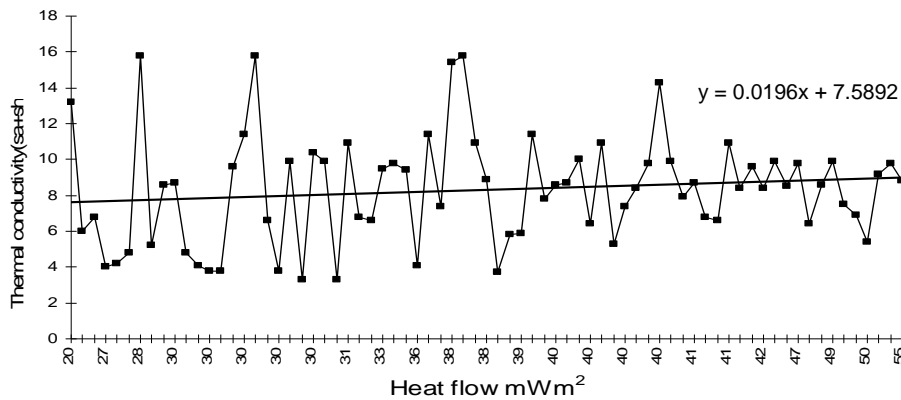

Figure 9: Heat Flow vs Thermal Conductivity (sa+sh) Benni Formation..

These boundaries suggest a difference between crustal blocks, characterized by contrasting heat generation. However, correlation with the regional magnetic anomaly signature Pilkington, (2000), corresponding to units of the cratonic basement, is not obvious at this scale.

Heat flow variations correspond to variations in geothermal gradient. Regional gradients are lowest (0.82°C/100m) at the central part of the Delta and increases both seaward and northward up to 2.62°C/100m and 2.95°C/100m respectively in the continental sands of the Benin formation. In the marine paralic deposition, geothermal gradients range from 1.83°C/100m to 3.0°C/100m at the central portions. The highest values of 3.5°C/100m to 4.6°C/100m are seen northwards while intermediate values of 2.0°C/100m to 2.5°C/100m are recorded seaward. The thermal gradients are clearly influenced by the lithology or rate of sedimentation in the area. Regions of low thermal gradients correspond with areas of high sand percentage, primarily because sands are better conductors than shale and therefore show as low thermal gradients, Akpabio et al. (2003).

CONCLUSIONS

1. Thermal conductivity varies with depth due to variable lithology and water content. From 8W/mk in the Benin formation to 5 W/mk in the marine shale formation.

2. Thermal conductivity calculations were based on assumed matrix conductivity of sand 6.1W/mk and shale 2.1W/mk, predominant lithologies in the Niger Delta.
3. Heat flow derived from thermal conductivity estimates at the central part of the Delta is (20 – 30 mW/m²), it increases both seaward and northward to (40 - 55 mW/m²).
4. Thermal conductivity decreases with increases in temperature.
5. Thermal conductivity contrast between rock types is a shallow phenomenon.
6. Heat flow corresponds to variations in geothermal gradient.

Laboratory measurement on core would further lay credence to the values of thermal conductivity obtained in this work.

ACKNOWLEDGEMENTS

The author is thankful to SPDC, Nigeria for allowing the use of their facilities and access to the data on which this study was based.

REFERENCES

1. Akpabio, I.O. 1997. "Thermal State of the Niger Delta Basin". Ph.D. Thesis. Rivers State University of Science and Technology: Port Harcourt, Nigeria.
2. Akpabio, I.O. and Ejedawe, J.E. 2001. "Temperature Variations in the Niger Delta Subsurface from Continuous Temperature Logs". *Global Journal of Pure and Applied Sciences*. 7(1):137 – 142.
3. Akpabio, I.O., Ejedawe, J.E., Ebeniro, J.O., and Uko E.D. 2003. "Geothermal Gradients in the Niger Delta Basin from Continuous Temperature Logs". *Global Journal of Pure and Applied Sciences*. 9(2):265 – 272.
4. Berge, P.A., Bomer, B.P., and Berryman, J.G. 1995. "Ultrasonic Velocity Porosity Relationship for Sandstones Analog made from Fused Glass Beads". *Geophysics*. 60(1):108 – 119.
5. Briguad, F., Chapman, D.S., and Douaran, S.L. 1990. "Estimating Thermal Conductivity in Sedimentary Basins using Lithologic Data and Geophysical Well Logs". *AAPG*. 74(9):1459 – 1477.
6. Chapman, D.S., Keho, T.H., Bauer, M.S., and Picard, M.D. 1984. "Heat Flow in the Uinta Basin Determined from BHT Data". *Geophysics*. 49(4):453 – 466.
7. Davies, M.G., Chapman, D.S., Van Wagoner, T.M. and Armstrong, P.A. 2007. "Thermal Conductivity Anisotropy of Metasedimentary and Igneous Rocks". *Journal of Geophysical Research*. 112. B05216, doi:10.1029/2006 JB004755.
8. Ejedawe, J. 1997. LITHTEMP, pers comm. Exploration Department, Shell Petroleum Development Company, Warri, Nigeria.
9. Kim, Hyung C. and Lee Youngmin. 2007. "Heat Flow in the Republic of Korea". *Journal of Geophysical Research*. 112, B05413, doi:10.1029/2006JB004266.
10. Majorowicz, J., Jessop, A., Lane, M., and Larry S. 2005. "Regional Heat Flow Pattern and Lithospheric Geotherms in Northeastern British Columbia and Adjacent Northwest Territories, Canada". *Bulletin of Canadian Petroleum Geology*. 53(1):51-66.
11. Norden, B. and Forster, A. 2006. "Thermal Conductivity and Radiogenic Heat Production of Sedimentary and Magmatic Rocks in the Northeast German Basin". *AAPG Bulletin*. 90(6):939 – 962.
12. Pilkington, M., Miles, W.F., Ross, G.M., and Roest, W.R. 2000 "Potential-Field Signatures of Buried Precambrian Basement in the Western Canada Sedimentary Basin". *Canadian Journal of Earth Sciences*. 37: 1453–1471.
13. Pribnow, D. and T. Umsonst. 1993. "Estimation of Thermal Conductivity from the Mineral Composition: Influence of Fabric and Anisotropy". *Geophysics, Res. Lett.* 20: 2199 – 2202.
14. Reijers, T.J.A., Petters, S.W., and Nwajide, C.S. 1997. "The Niger Delta Basin". In: Selley, R.C. (editor). *African Basins, Sedimentary Basins of the World*. 3:145 – 172.
15. Zielinski, G.W., Bjoroy, M.Z., Robyn, L.B. and Ferriday, I.L. 2007. "Heat Flow and Surface Hydrocarbons on the Brunei Continental Margin". *AAPG Bulletin*. 91:1053-1080

ABOUT THE AUTHOR

Idara O. Akpabio works as a Research Advisor in the Exploration Department of Shell Petroleum Development Company, Port Harcourt, Nigeria. He is a Senior Lecturer in Geophysics/Physics Department, University of Uyo, Nigeria. He holds an M.Sc. in Mineral Exploration (Geophysics Option) from the University of Ibadan, Nigeria and a Ph.D. (Applied Geophysics) from the University of Science & Tech., Port Harcourt.

SUGGESTED CITATION

Akpabio, I.O. 2009. "Thermal Conductivity Estimates in the Niger Delta Using Lithological Data and Geophysical Well Logs". *Pacific Journal of Science and Technology*. 10(1):701-709.



[Pacific Journal of Science and Technology](http://www.akamaiuniversity.us/PJST.htm)