

Fault Detection and Diagnosis for DC Motor in Robot Movement System using Neural Network.

A. Che Soh, M.Sc.* and R.Z. Abdul Rahman, M.Eng.

Department of Electrical and Electronic Engineering,
Universiti Putra Malaysia, Serdang, Malaysia.

E-mail: azura@eng.upm.edu.my*

ABSTRACT

Most of intelligent control in movement control involves fuzzy logic and neural network systems. In this research, a neural network is used to detect and diagnose the faults that may occur in a DC motor system during robot operations. The DC motor system is constructed using the SIMULINK® toolbox. This system provides the normal and faulty data that has been used for training purpose in the neural network system to get the normal and faulty models. Finally, from the simulation results, the neural network is able to recognize the system characteristic whether in normal conditions or faulty conditions.

(Keywords: intelligent control, neural network, digital controller, DC motor, robot movement)

INTRODUCTION

A fault diagnosis system should perform two tasks, namely fault detection and fault isolation. The purpose of the former is to determine whether a fault has occurred in the system. To achieve this goal, all the available information from the system should be collected and processed to detect any changes from the nominal behavior of the process. The second task is devoted to locate the fault source [4], [5].

Artificial intelligence systems are one among the newest scientific fields in the world that can be used in fault diagnosis. A neural network is one of the branches of the artificial intelligence besides the fuzzy logic system, experts system and multivariate regression [1], [2], [3]. There is lot of research which is related to neural networks and some have been applied in real life.

Design and development in robotic systems has become an important field in engineering

industries due to the requirement of high performance autonomous machines used to increase production and handle duty under tough environments.

In this research, the system is specifically designed to define robotic movement. Generally, the design task can be divided into five parts: movement systems, sensor systems, power systems, controller circuits, and mechanical construction of the robot. However, only movement, sensor, and controller system designs are involved in this simulation. A robot movement system can be designed using DC servo motors, AC motors, or pneumatic systems. Motors are normally used for joints and the robot's wheel construction because of their small size and ease of control.

This study focus on the detection and diagnosis for DC motors in the robot design. This is because the motor is the main part of the robot design. The neural network is used to detect and diagnosis the fault during the operation of DC servo motors, so that the designed system can be improved. The problem will be overcome quickly if the fault can be detected early.

Simulation and analysis of this robotic movement control system provides designers with information on how the neural network method can affect the output speed and stability of the system. From this information, designers can proceed with a larger design and with more complex controller systems.

ROBOT MOVEMENT SYSTEM

The robot movement system designed for this project is based on a few subsystems normally available in most digitally controlled movement design technology. The speed system is the DC

motor subsystem. This system can be divided into two parts, the mechanical system and electrical system. Both systems are designed to be controlled by a digital controller subsystem.

The sensor subsystem is designed to interact with the digital controller subsystem. The sensor subsystem provides the digital controller subsystem with all information or signal about the environment condition. From this information or signals, the digital controller is expected to be able to control the DC motor subsystem rotation speed. Input switching subsystems is designed to turn on or turn off the motor [6], [7],[8].

The DC motor subsystem is the main component that decides how fast the robotic system will move. This subsystem is connected to the mechanical movement system of the designed robot. Speed control of a robotic design is always based on how or which type of motor system are to be developed. Various types of motors can be used to move the robot joints, robot base system, robot arms, etc. For a simple design, designers normally choose to use either DC servomotors or step motors. In this study, a digital controlled DC motor model was chosen for the robotic speed control system design.

The basic structure of a DC motor can be divided into two parts; the voltage controlled circuitry and mechanical rotor. The motor torque provides the movement over inertia for the rotor system. If the motor initially is in a static condition, it requires a larger torque value to start the motor. If the motor initially is in a moving condition, the inertia of the motor will sum up with the system torque to give a grater rotation, which will further increase the moment speed of this system.

The velocity of the motor can be defined as the rate of change in rotor position, θ .

$$\text{Motor Velocity} = \frac{d\theta}{dt} \quad (1)$$

From the study of Newton's law, the motor rotation angle characteristic can be defined as:

$$J \frac{d^2\theta}{dt^2} = T - b \frac{d\theta}{dt} \quad (2)$$

Whereby:

J = moment of inertia of the rotor,
 T = motor torque,

B =damping ratio of the mechanical system,

$\frac{d^2\theta}{dt}$ = rotational acceleration and

$\frac{d\theta}{dt}$ = rotational velocity.

This equation for motor rotation characteristic was further simplified to:

$$\frac{d^2\theta}{dt^2} = \frac{1}{J} \left(K_t i - b \frac{d\theta}{dt} \right) \quad (3)$$

The second equation that needs to be taken into consideration is the DC motor equivalent circuit characteristic equation. Using the Kirchoff's Law, the circuit equivalent equation can be developed as shown below:

$$\text{Start: } L \frac{di}{dt} = -Ri + V - e \quad (4)$$

$$\frac{di}{dt} = \frac{1}{L} \left(-Ri + V - K_e \frac{d\theta}{dt} \right) \quad (5)$$

Whereby:

L is electric inductance, R is electric resistance, V is applied voltage source and K_e motor constant.

The DC motor subsystem model is designed using a SIMULINK® block diagram as shown in Figure 1. From the figure, a few blocks are set as constant parameters, namely the K (electromotive force constant), R (electric resistance), J (moment of inertia of the rotor), L (electric inductance), and b (damping ratio of the mechanical system). The parameters' values used for this simulation are taken from an experiment done on an actual motor in the Carnegie Mellon undergraduate controls lab [9] as shown below:

$$J = 0.01 \text{kgm}^2 \text{s}^{-2}$$

$$b = 0.1 \text{Nm/s}$$

$$K = K_e = K_t = 0.01 \text{Nm/Amp}^{-1}$$

$$R = 1 \Omega$$

$$L = 0.5 \text{H}$$

Details about the digital controller system are not taken into consideration in this study. From

previous studies by Carnegie Mellon's undergraduate controls lab [9], the digital controller of this system can be represented in a transfer function as shown below:

$$= 450 \frac{(z - 0.85)(z - 0.085)}{(z + 0.98)(z - 0.7)} \quad (6)$$

Digital Controller:

The feedback system with unity gain is designed for the feedback loop of the digital controlled motor system as shown in Figure 2. This model can be used to represent the basic movement system of a robotic design. Any robotic system using a DC source controlled motor requires a similar system as shown in this design. The only thing that may be different is the parameter value of each part or block of the model

FAULT DETECTION AND DIAGNOSIS FOR DC MOTOR IN ROBOT MOVEMENT SYSTEM

The main idea in this simulation is to get the movement patterns from the robot, with which to move forward, turn right, turn left, and move backwards. Two motors are used to move the robot and get these patterns. Figure 3, as shown below, is the illustration of the mobile platform of the robot model for this project. The place or position of the motor and sensor in this robot is shown in Figure 4.

From Figure 4, two DC motors which control the movement of the robot. Right motor is for right wheels and left motor for left wheels. The movement of the robot is also controlled by two sensor, left sensor and right sensor. The right sensor is connected to left motor and left sensor is connected to right motor.

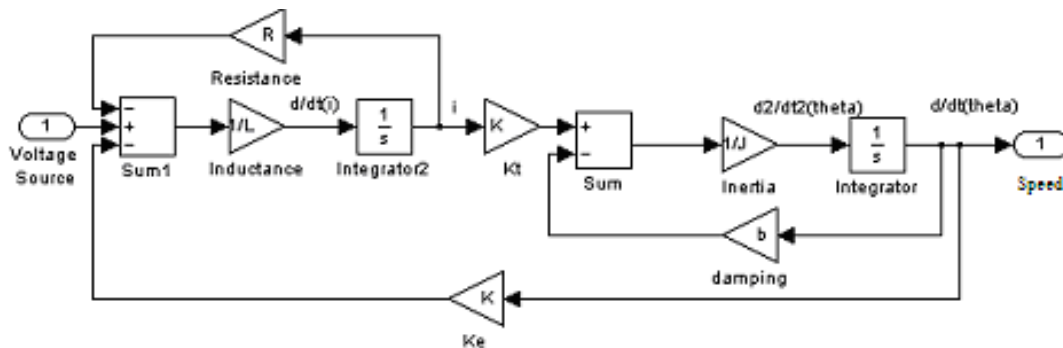

Figure 1: SIMULINK Block Diagram for the Subsystem of a DC Motor.

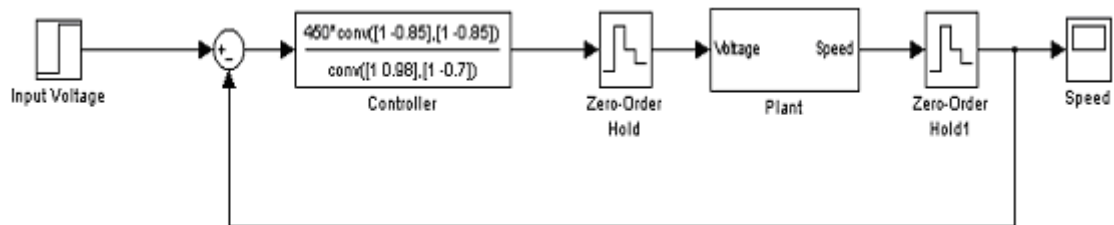

Figure 2: DC Motor System with Digital Controller.

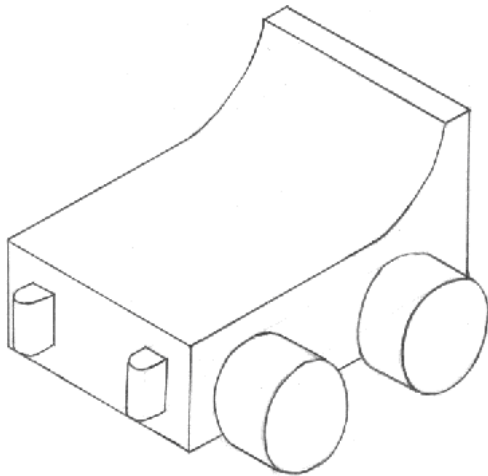

Figure 3: Model of the Mobile Platform.

Every robotic system should have sensors to sense and check the dynamic environment conditions in the real time design. In this design, the sensor system is developed to sense obstacles in the robotic movement path. For digital systems, the sensors can only detect if either the obstacle is present (logic '1') or not present (logic '0'), as discussed before.

Another parameter which needs to be taken into consideration is the rate of change in the sensor input. This can be represented in a derivative value of the sensor output voltage (dV/dt). The gain parameter of the sensor system was added to the system to control of the output parameter of the whole system. A greater gain value will give better control over the output of the system.

In this project, the movement system depends on DC motors and sensors. If one of the motors or sensors has malfunctioned, the robot may not be able to move or may move in the wrong direction. So, the fault for the system needs to detect and diagnosis for improvements back to the system.

This project just focuses on detection and diagnosis for the DC motor system because the motor is the main motive system for the robot. Neural networks are used to find the aim of this project. Fault detection and diagnosis for the DC motor in this robotic system are divided into five parts:

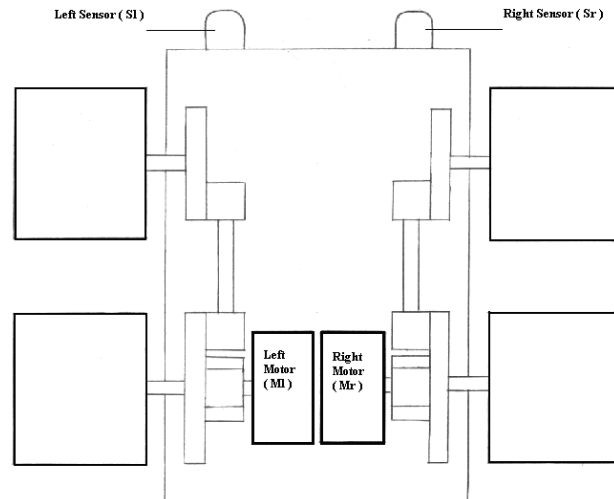

Figure 4: Position of the DC Motors and Sensors in the Robotic Model.

- Normal condition.
- Fault condition, motor resistance increased by 10%.
- Fault condition, motor resistance decreased by 10%.
- Fault condition, motor inductance increased by 10%.
- Fault condition, motor inductance decreased by 10%.

The input of the system is the rate of change in the sensor's signal (dV/dt). The SIMULINK block diagram for the whole robotic system with two sensors and two DC motors is shown in Figure 5. The right sensor is connected to left motor and left sensor is connected to right motor.

The system has been modified by replace the step input to uniform random input with the Zero Order Hold. The modified model of the system is shown in Figure 6. This modified system is required to generate the random input to the system. VLd, VRd, SLd, and SRd are the four values used to train the network and the values of SLd and SRd are the target for neural network.

RESULTS AND DISCUSSIONS

Scenarios / Simulation of Robot Movement:

The first part, the robot movement system will be simulated under normal conditions to describe the movement of robot.

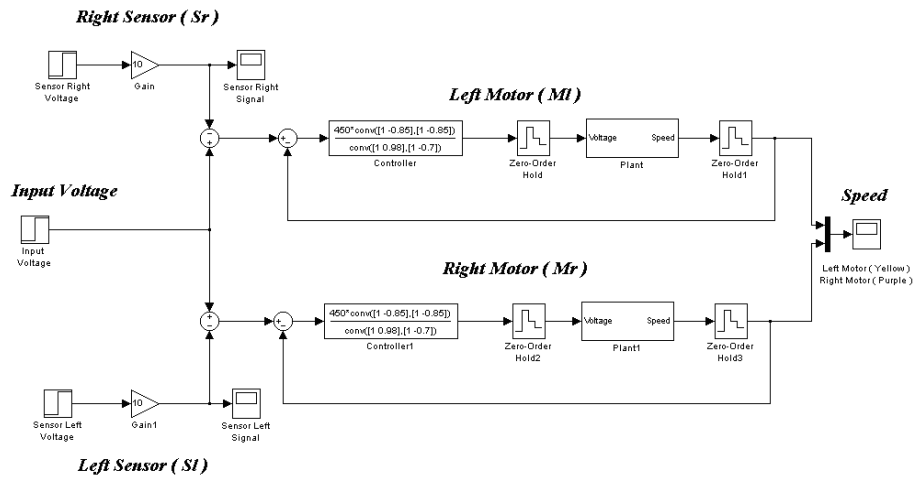

Figure 5: Robot Movement System SIMULINK Block Diagram.

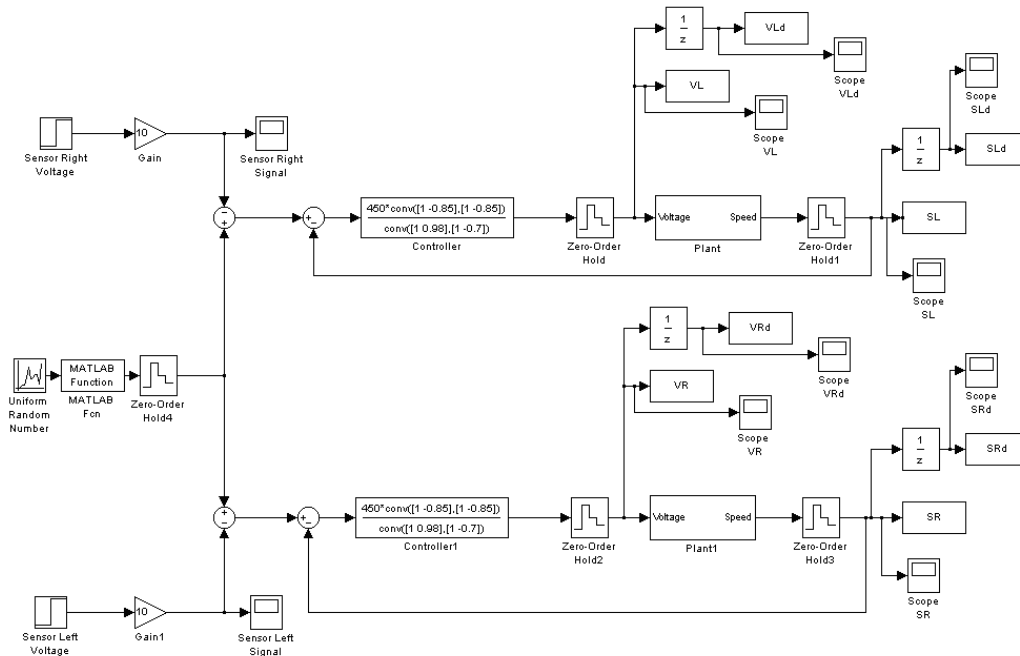

Figure 6: Modified Robot Movement System in SIMULINK Block Diagram.

The robot will move forward when the both sensors are not detecting any obstacle, then both motors will be rotated on forward. If the left sensor detects an obstacle, the right motor will be rotated to reverse and the left motor will still be in the forward rotation; so, the robot turns right.

The robot will turn left when the right sensor detects an obstacle with the left motor rotated on

reverse and the right rotated on forward. If the both sensors detect an obstacle, then both motors will rotated on reverse; so, the robot moves backward.

Figure 7, Figure 8, Figure 9, and Figure 10 as shown below from the simulation to show the movement of the robot system.

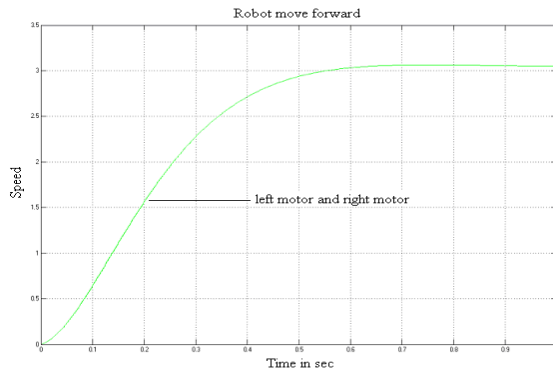

Figure 7: Graph for Robot Forward Movement.

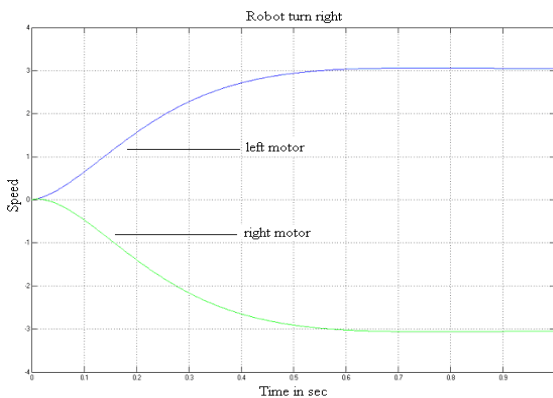

Figure 8: Graph for Robot Right Turn.

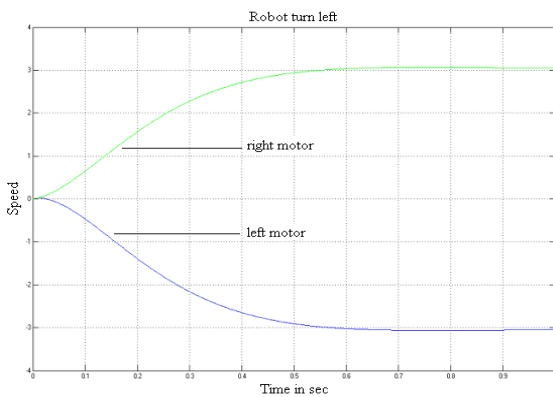

Figure 9: Graph for Robot Left Turn.

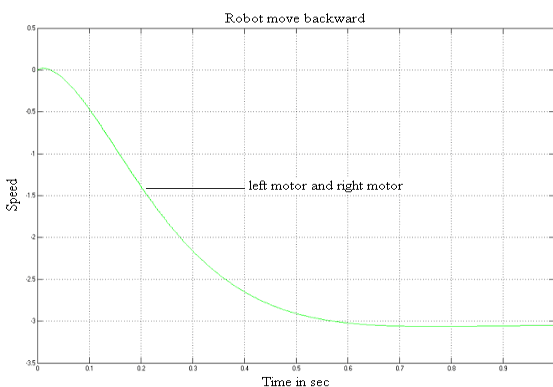

Figure 10: Graph for Robot Backwards Movement.

SIMULATION OF FAULT DETECTION AND DIAGNOSIS FOR DC MOTOR USING NEURAL NETWORK

The results of the neural network of the DC motor system can be divided into five parts as discussed in section above. The performance of the network that has been trained is related to the error output. The performance of the network is poorer if the performance value of the network is larger. Table 1 shows the summary performance values or indexes for the all conditions as discussed above.

Table 1: Performance Index for Normal and Fault Conditions.

Condition	Performance Index (10^{-10})
Normal	3.00346
+ R 10%	203907.0
- R 10%	223691.0
+ L 10%	48.9277
- L 10%	1757560.0

From the data in the Table 1, the performance index of the normal condition is set as reference or target. The performance index is poorer if the performance value is larger. As a result, all of the performance values for all conditions are good because they have small values, approximate to zero.

The performances index for fault conditions in the changes of resistance (increase and decrease) is poorer than the changes of inductance (increase and decrease). Although the performance values of decreases of inductance is higher but its epoch is smaller than all conditions.

Error = target data – output data

Output errors are the target data minus the output data. The two variables are error of SL and error of SR. Both variables are separated and will be plotted individually versus time. All of the fault conditions and the normal condition are plotted as shown in Figures 11 through 20.

Errors of the *Robot* (neural network model for robot movement system) under normal conditions are shown in Figure 11 and Figure 12 and the errors that occurred are approximately zero for the *Robot* error, SL and SR. Errors of the *Robot* with +10% faults at R condition are shown in Figure 13 and Figure 14 and the errors that

occurred are approximately +0.1. Errors of the Robot with -10% faults at R condition are shown in Figure 15 and 16 and the errors that occurred are approximately -0.1.

Errors of the Robot with +10% faults at L condition are shown in Figure 17 and Figure 18 and the errors that occurred are approximately zero. Errors of the Robot with -10% faults at L condition are shown in Figure 19 and Figure 20 and the errors that occurred are approximately zero.

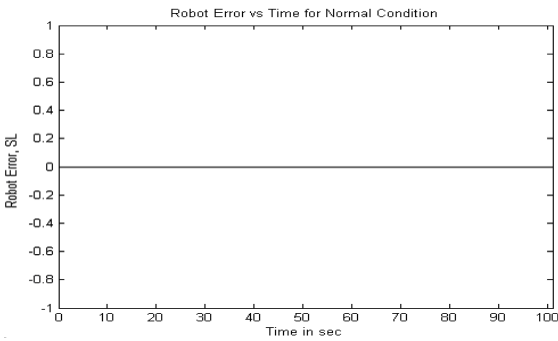

Figure 11: Normal Condition for SL.

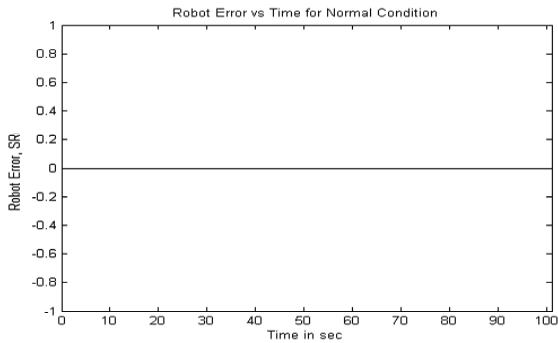

Figure 12: Normal Condition for SR.

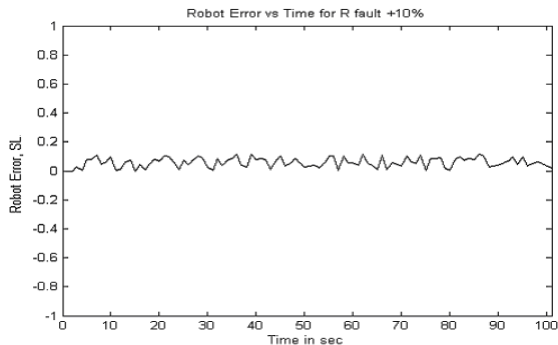

Figure 13: +10%R Fault Condition for SL.

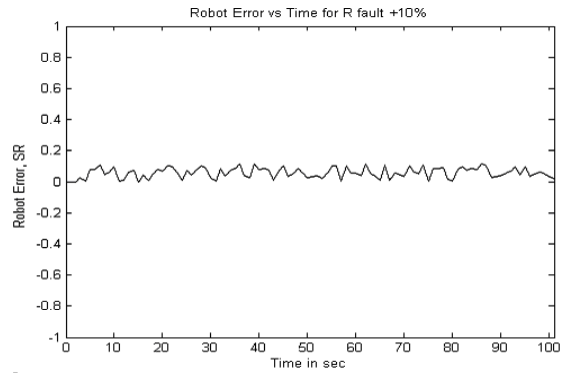

Figure 14: +10%R Fault Condition for SR.

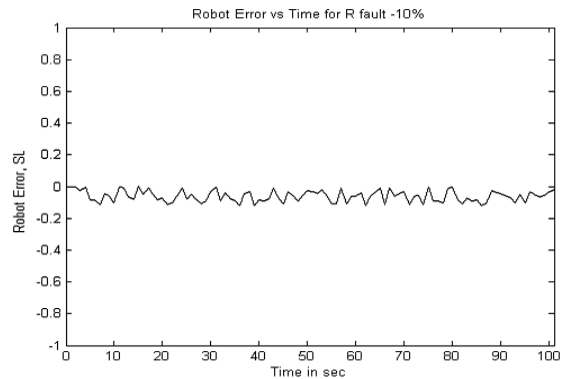

Figure 15: -10%R Fault Condition for SL.

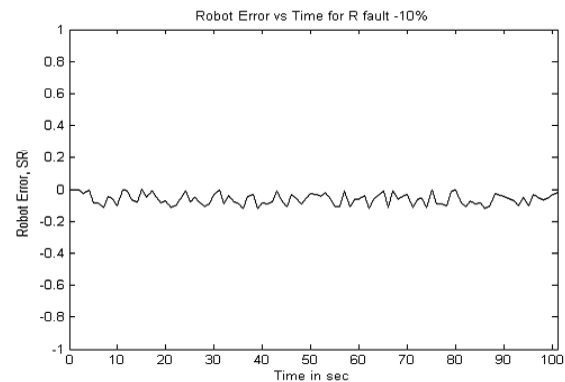

Figure 16: -10%R Fault Condition for SR.

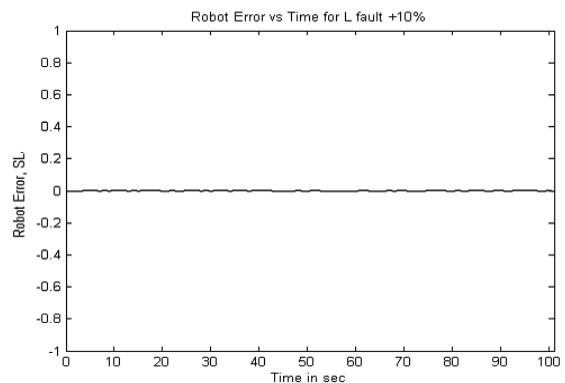

Figure 17: +10%L Fault Condition for SL.

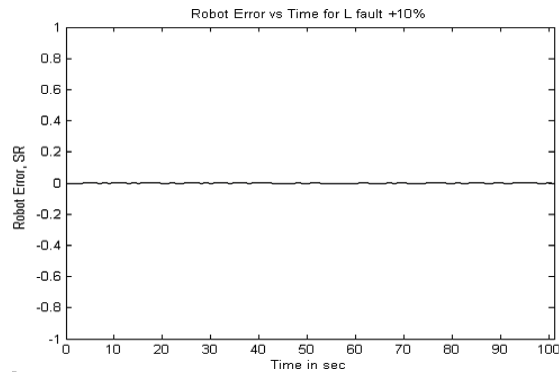

Figure 18: +10%L Fault Condition for SR.

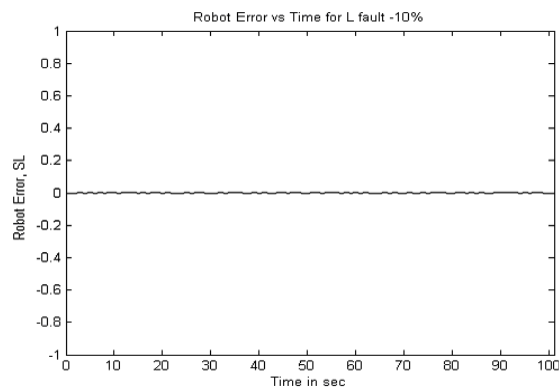

Figure 19: -10%L Fault Condition for SL.

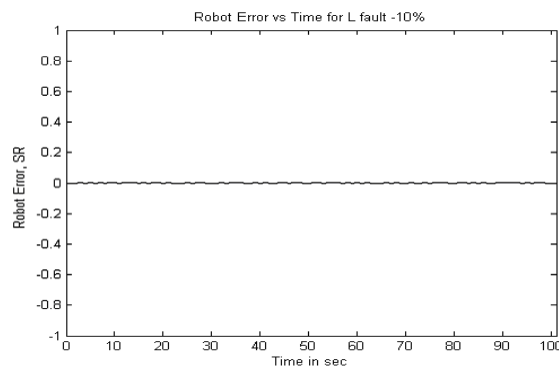

Figure 20: -10%L Fault Condition for SR.

CONCLUSIONS

This study presents a robot movement system where every movement is driven by two DC motors. Any faults from the motors have an impact on the movement of the robot. Faults must be removed early in order to avoid disruption to the process. Fast fault diagnosis becomes one of the key requirements for optimum operations.

A neural network is used to detect the faulty operations and diagnose the faults that may occur in the DC motor system. The DC motor system is constructed using the SIMULINK[®] toolbox. This system provides an input data to the neural network. These data will be used to train the network so that the network will be able to recognize the system characteristic whether in fault free condition or in faulty conditions.

The fault detection is performed using the plot of the output errors. This can be easily seen when the system is operating in normal condition and the errors for both robot output SL and SR are zero. However, if the system is operating in faulty condition, the errors of the robot outputs are non-zero. The fault is diagnosed by identifying the output errors of the robot network (amplitude error of SL and SR).

Feed-forward back-propagation is a multilayer neural network, which can successfully trace the faults and identify the nature of the problems that are implemented in this project. Weight, bias, number of hidden layers, and number of neurons in each layer are important in the development of a good network.

REFERENCES

1. Azura Che Soh, M.K. Hassan, and Li Hong Fey. 2004. "Intelligent Movement Control for Robots using Fuzzy Logic". International Conference Artificial Intelligence in Engineering and Technology (ICAET 2004). 3-5 Aug. 2004, Sabah, Malaysia.
2. Azura Che Soh, Erny Aznida Alwi, Ribhan Zafira Abdul Rahman, and Li Hong Fey. 2008. "Effect of Fuzzy Logic Controller Implementation on a Digitally Controlled Robot Movement". *Kathmandu University Journal of Engineering, Science and Technology*. 1(5):28-39.
3. Azura Che Soh, Mohd Khair Hassan, Mohd Amran Mohd Radzi, and Li Hong Fey. 2005. "Development of Fuzzy Logic Controller for Movement Control of Robotic System". *Journal of Industrial Technology*. 14(2):113-137.
4. Durkin, J. 1994. *Expert Systems Design and Development*. Macmillan Press: New York.
5. <http://www.engin.umich.edu/group/ctm/examples/motor/motor.html>.

6. King, R.E. 2004. *Computational Intelligence in Control Engineering*. Marcel Decker, Inc.: New York.
7. Kramer, M.A. 1987. "Malfunction Diagnosis using Quantitative Models with Non-Boolean Reasoning in Expert Systems". *A1ChE*. 33.
8. Carnegie Mellon University. 1996. "DC Motor Speed Modeling". CMU: Pittsburgh, PA.
9. Negnevitsky, M. 2004. *Artificial Intelligence: A Guide to Intelligent System*. Addison-Wesley: London, UK.
10. Patton R.J., Frank, P.M., and Clark R.N. 1989. *Faults Diagnosis in Dynamic Systems, Theory and Application*. Control Engineering Series, Prentice-Hall: New York, NY.

ABOUT THE AUTHORS

Che Soh, Azura, received her B.Eng. degree in Electronic/Computer and M.Sc. degree in Electrical and Electronics Engineering from the Universiti Putra Malaysia (UPM), Malaysia in 1998 and 2002, respectively. Her research interests include artificial intelligence, process control, control systems, robotics, and automation. Presently she is a Lecturer at the Universiti Putra Malaysia (UPM), Malaysia. She is currently pursuing her Ph.D. degree in intelligent urban traffic light control at Universiti Teknologi Malaysia (UTM), Malaysia.

Ribhan Zafira Abdul Rahman received her B.E. degree in Electrical and Electronics Engineering from the Liverpool John Moores University, United Kingdom in 1998, and her M.E. degree in Electrical Engineering from Universiti Teknologi Malaysia, Malaysia in 2001. Her research interests include artificial intelligence, process control, control systems, fault detection, and diagnosis. Presently, she is a lecturer at Universiti Putra Malaysia, Malaysia. She is currently pursuing her PhD degree in fault detection and diagnosis at Universiti Teknologi, Malaysia.

SUGGESTED CITATION

Che Soh, A.. and R.Z. Abdul Rahman. 2009. "Fault Detection and Diagnosis for DC Motor in Robot Movement System using Neural Network". *Pacific Journal of Science and Technology*. 10(1):35-43.



[Pacific Journal of Science and Technology](http://www.akamaiuniversity.us/PJST.htm)